

# Turbomat

TM 150/220

TM 320/500



# High-Tech solutions without boundaries



Right from the beginning, Froling has specialised in the efficient use of wood as an energy source. Today the Froling name stands for the latest in biomass heating technology. Our firewood, wood chip and pellet boilers are used successfully across Europe. All products are produced at our own factories in Austria and Germany. The excellent coverage of Froling's service network ensures reliability.

## **The fuels: wood chips, shavings or pellets**



Wood chips are a fuel that is domestically produced, unaffected by crises, and environmentally friendly. The production of wood chips also guarantees domestic jobs. That is why wood chips are the perfect fuel, not just economically, but also from an ecological perspective. Scrap wood in the form of branches, tree-tops and sawmill waste is broken down to wood chips with shredders. Depending on the wood used, there are various quality classes.



Wood pellets are made from natural wood. The wood shavings and sawdust produced in large quantities as a by-product in the wood processing industry are compacted and pelleted in an untreated state. Pellets have a high energy density and are easy to deliver and store. These are just some of the advantages that make pellets the perfect fuel for fully automatic heating systems. Pellets are delivered by tanker, which unloads the pellets directly into the store.

# Turbomat Kommunal

## Invest in the future

The Froling Turbomat is a unique heating system with a fully automatic wood burner which will operate with a wide variety of wooden material. As a leading manufacturer of biomass heating systems, Froling brought in all their expertise in forward-looking innovation for the Turbomat. The idea was to develop a boiler that would be perfectly suited for burning other biomass fuels as well as wood chips.

The Turbomat is not just visually appealing - it also has an impressive control system. With Lambda controls as standard, combustion chamber temperature monitoring and under-pressure control, perfect combustion is guaranteed for a range of materials. It is just as **user-friendly** as oil or gas boilers.

All Turbomat functions are **fully automatic**, from the fuel feed and combustion control, right through to cleaning and ash removal. The high-tech Turbomat is designed to be extremely **easy to service**.





# A design with unique benefits

TURBOMAT Kommunal 150/220



- 1** Trapezoidal stoker duct for minimal feed resistance.  
A water-cooled slide-in duct is available for the TM 220 to minimise the wear from the high temperatures in the slide-in area.
- 2** 4-shelled high-temperature combustion chamber for clean combustion even with damp material or alternative fuels, such as miscanthus.
- 3** Moving conveyor grate for maintenance-free and fault-free operation.
- 4** Automatic ash removal for transport into easily removable ash containers.
- 5** Vertical 3-pass heat exchanger and Efficiency Optimisation System (WOS) with automatically operated turbulators for cleaning and for minimal dust emissions ( $<50\text{mg}/\text{Nm}^3$ ).
- 6** Optional flue gas recirculation for optimisation of combustion and output.
- 7** Multi-layer heat insulation for extremely low radiant heat losses.
- 8** Large boiler doors for easy cleaning.

# Turbomat Kommunal

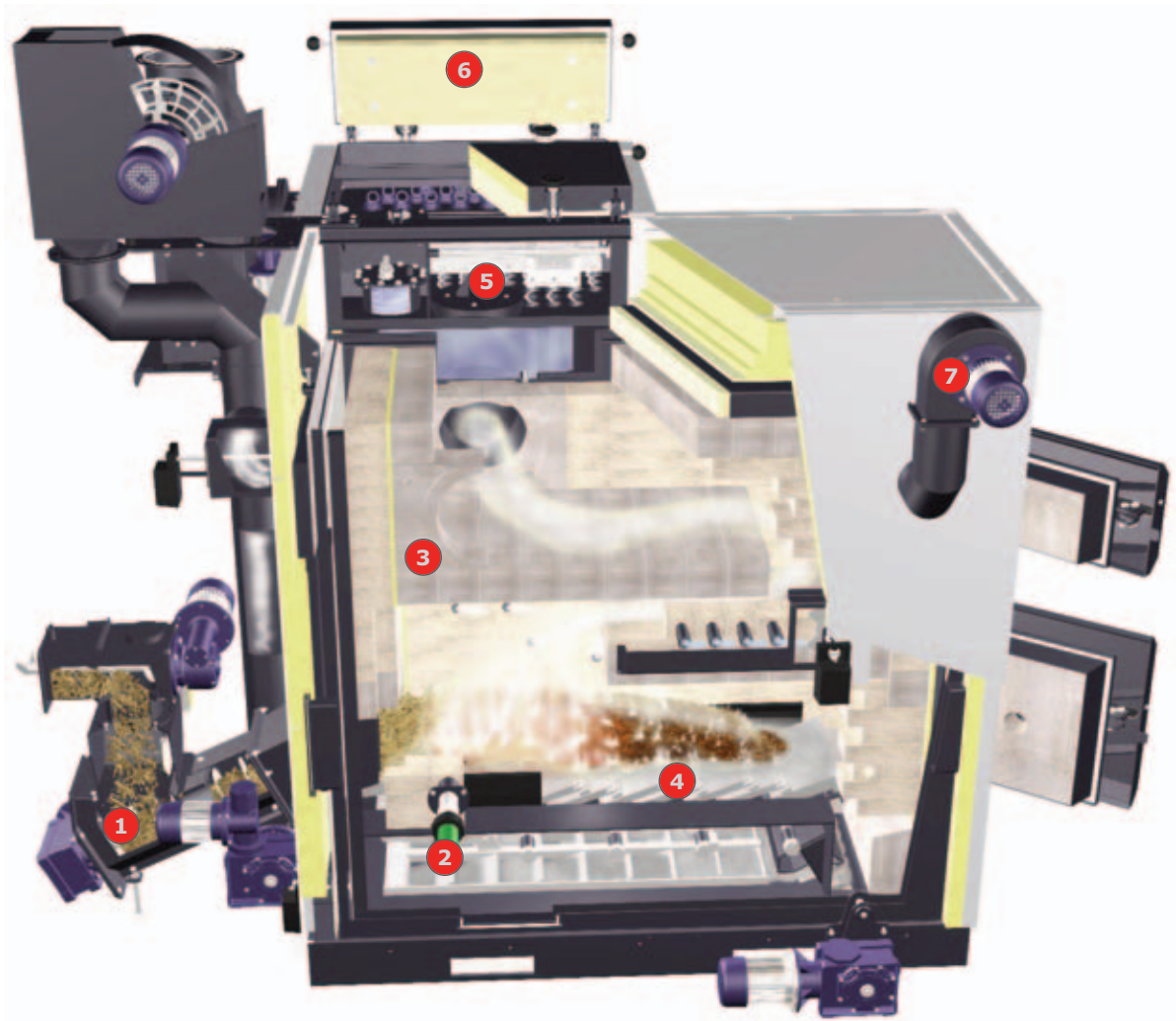

TURBOMAT Kommunal 320/500

- 1 Divided trapezoidal stoker duct for extremely low feed resistance and water-cooled slide-in duct to minimise wear from the high temperatures in the slide-in area. There is also the option of hydraulic infeed (G100).
- 2 Optional second ignition fan for damp heating material that is hard to light.
- 3 High-temperature resistant fireclay retort for clean combustion, even with damp or alternative fuels, such as miscanthus.
- 4 Primary air zone separation for optimum burn-off and low emissions (CO as low as less than 10mg/MJ!).
- 5 Vertical 4-pass heat exchanger with integrated cyclone dust separator and Efficiency Optimisation System (WOS) with automatically activated turbulators for cleaning.
- 6 Divided heat exchanger cover for problem-free cleaning.
- 7 Jacket cooling for minimum radiant heat loss and increased efficiency.

# Well planned in every detail

**Feature:** **High temperature combustion chamber with conveyor grate**

- Benefits:
- No cinder build-up
  - Optimum burnout
  - Very low emissions
  - Automatic ash removal

The high-temperature combustion chamber is 4-shelled, guaranteeing clean combustion. The jacket cooling, together with the water-cooled slide-in duct, minimise the loss of radiant heat and guarantee high efficiency. Thanks to the moving conveyor grate, boiler operation is trouble- and maintenance-free, even when using low-grade fuels which tend to form cinder. Separation of the primary air zone guarantees full, efficient burnout. This keeps emission levels very low (CO less than 10 mg/MJ). The ashes that fall under the grate are automatically transported to the ash container by a rake.

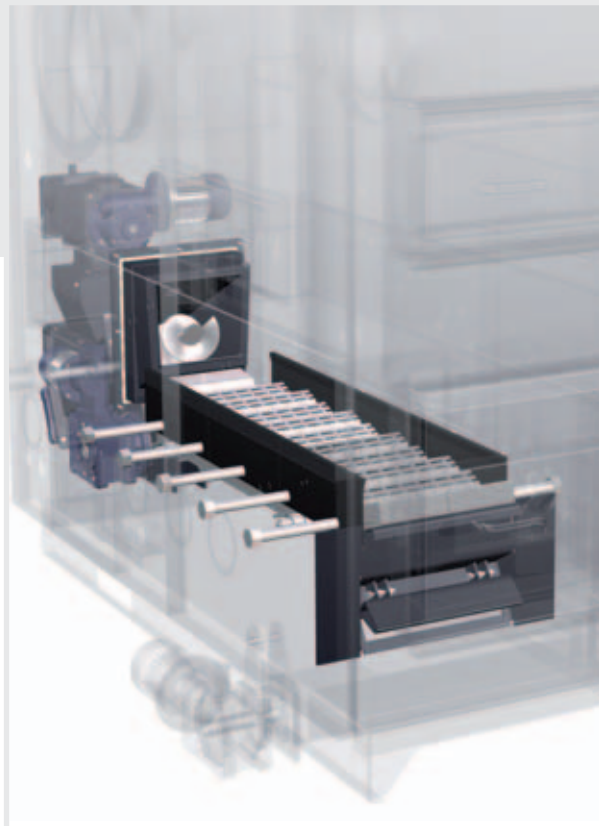

**Feature:** **Upright heat exchanger**

- Benefits:
- Optimal heat transfer
  - Automatic cleaning of heating surfaces
  - High efficiency
  - Very low dust emissions

The upright design means that the heat-exchanger practically cleans itself. The heating surfaces can also be cleaned automatically, which means high efficiency. The safety battery, which is installed as standard, prevents overheating. The patented multi-cyclone dust separator integrated in the heat exchanger of the Turbomat 320 and 500 ensures that the lowest dust emission limit values are observed. Ash is removed by sturdy screws, which feed it into containers. These are outside the unit, so they are easy to remove and empty.

# Turbomat Kommunal

## **Feature:** Service-friendly sturdy design

- Benefits:
- Maintenance work kept to a minimum
  - Components are easy to replace
  - Cost savings
  - Extremely high operating safety

The high-tech Turbomat is easy to service. All components, from the fire bricks to the grate elements, are easy to replace and inexpensive. The built-in burn back flap or rotary valve, combined with the under-pressure monitoring system, ensures safe operation.

The Turbomat 320 and 500 are available in versions with a second retort for use with very dry fuel, such as joinery material (see Turbomat Industrie).

In case of eventualities you can continue emergency operation by connecting up an oil burner or a gas burner.

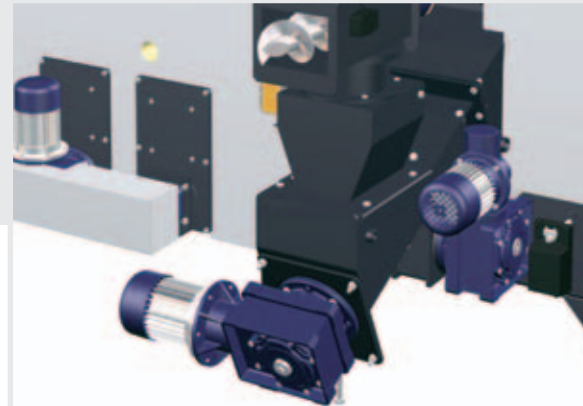

## **Feature:** Flue gas recirculation

- Benefits:
- Combustion optimisation
  - Even longer service life

A portion of the flue gas is fed back into the combustion with a speed-regulated flue gas return blower fan. The flue gas is dosed into primary and secondary flue gas return using progressive rotary slide valves. This reduces the NOx emissions. Using high quality, dry fuels also protects the fireclay. Combustion and output are optimised for both damp and dry fuels.



# Technical specifications

## Performance data - TM Kommunal 150/220

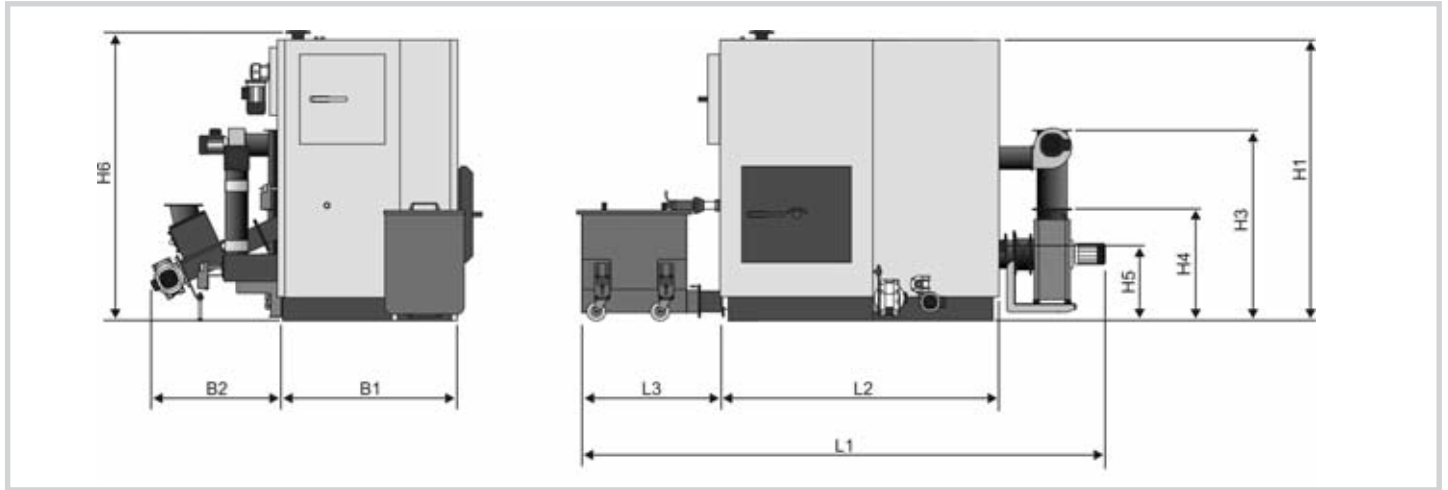

DIMENSIONS			TM 150	TM 220
H1	Height of boiler	[mm]	1875	1875
H2	Total height with flue gas return (with heat exchanger, left)*	[mm]	2280	2280
H3	Height of flue gas pipe connection with flue gas return	[mm]	1270	1380
H4	Height of flue gas pipe connection	[mm]	750	1060
H5	Height of return feed connection	[mm]	495	495
H6	Height of outfeed connection	[mm]	1930	1930
W1	Width of boiler	[mm]	1200	1485
B2	Width of stoker (inc. gears)	[mm]	845	895
L1	Total length of the system	[mm]	3595	3685
L2	Total length of boiler	[mm]	1865	1910
L3	Length of ash trolley	[mm]	930	930

TECHNICAL SPECIFICATIONS			TM 150	TM 220
Rated heat output (woodchips W30 as per ÖNORM)	[kW]		150	220
Required fuel consumption at rated load (G50/W20)	[kg/h]		42	62
Weight - boiler	[kg]		1925	2655
Flue gas pipe diameter	[mm]		200	250
Water capacity	[L]		440	570
Maximum permitted boiler operating temperature	[°C]		110	110
Minimum return feed temperature	[°C]		65	65
Maximum permitted operating pressure	[bar]		3	3
Flue gas temperature at rated load	[°C]		190	190



# Turbomat Kommunal

## Performance data - TM Kommunal 320/500

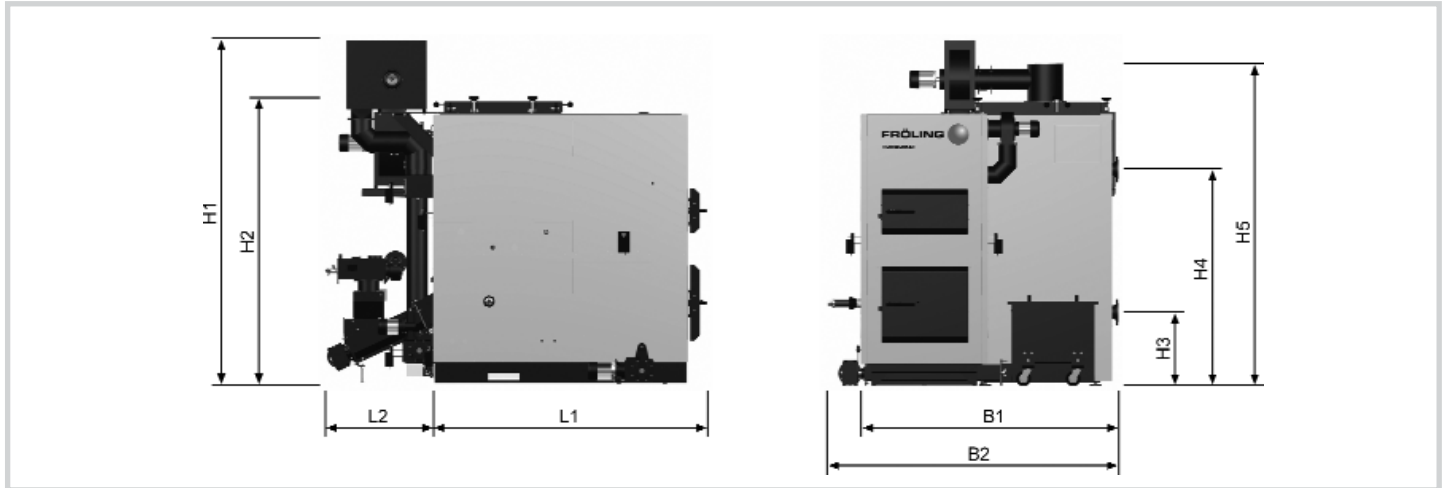

DIMENSIONS			TM 320	TM 500
H1	Total height with flue gas return	[mm]	2940	3075
H2	Total height without flue gas return	[mm]	2440	2605
H3	Height of return feed connection	[mm]	620	690
H4	Height of outfeed connection	[mm]	1830	1980
H5	Height of flue gas pipe connection	[mm]	2730	2910
W1	Width of boiler	[mm]	2170	2550
B2	Total width of the system	[mm]	2600	2980
L1	Length of boiler	[mm]	2325	2590
L2	Length of stoker unit	[mm]	925	1010

TECHNICAL SPECIFICATIONS			TM 320	TM 500
Rated heat output (woodchips W30 as per ÖNORM)		[kW]	320	500
Required fuel consumption at rated load (G50/W20)		[kg/h]	110	172
Flue gas pipe diameter		[mm]	300	350
Diameter of stoker screw		[mm]	150	200
Weight - boiler		[kg]	5070	6800
Water capacity		[L]	560	750
Maximum permitted boiler operating temperature		[°C]	110	110
Minimum return feed temperature		[°C]	65	65
Maximum permitted operating pressure		[bar]	6	6
Flue gas temperature at rated load		[°C]	140	140

# Forward-looking boiler technology

## The new Froling Turbomat Industrie

The new Turbomat Industrie from Froling offers a complete design that meets all your needs.

New boiler technology for high-quality, dry fuels with a high heating value (pellets, joinery material) is impressively innovative.

The shape of the combustion chamber, the grate system and air supply are optimally adjusted for the relevant fuel.

The newly developed troughed underfeed stoker and the modular conveyor grate, which moves over all grating rows, ensure an even glowing ember bed and excellent emission values.

The optional flue gas return is integrated to the boiler insulation. This makes it simpler to assemble and saves expenses for additional insulation measures.



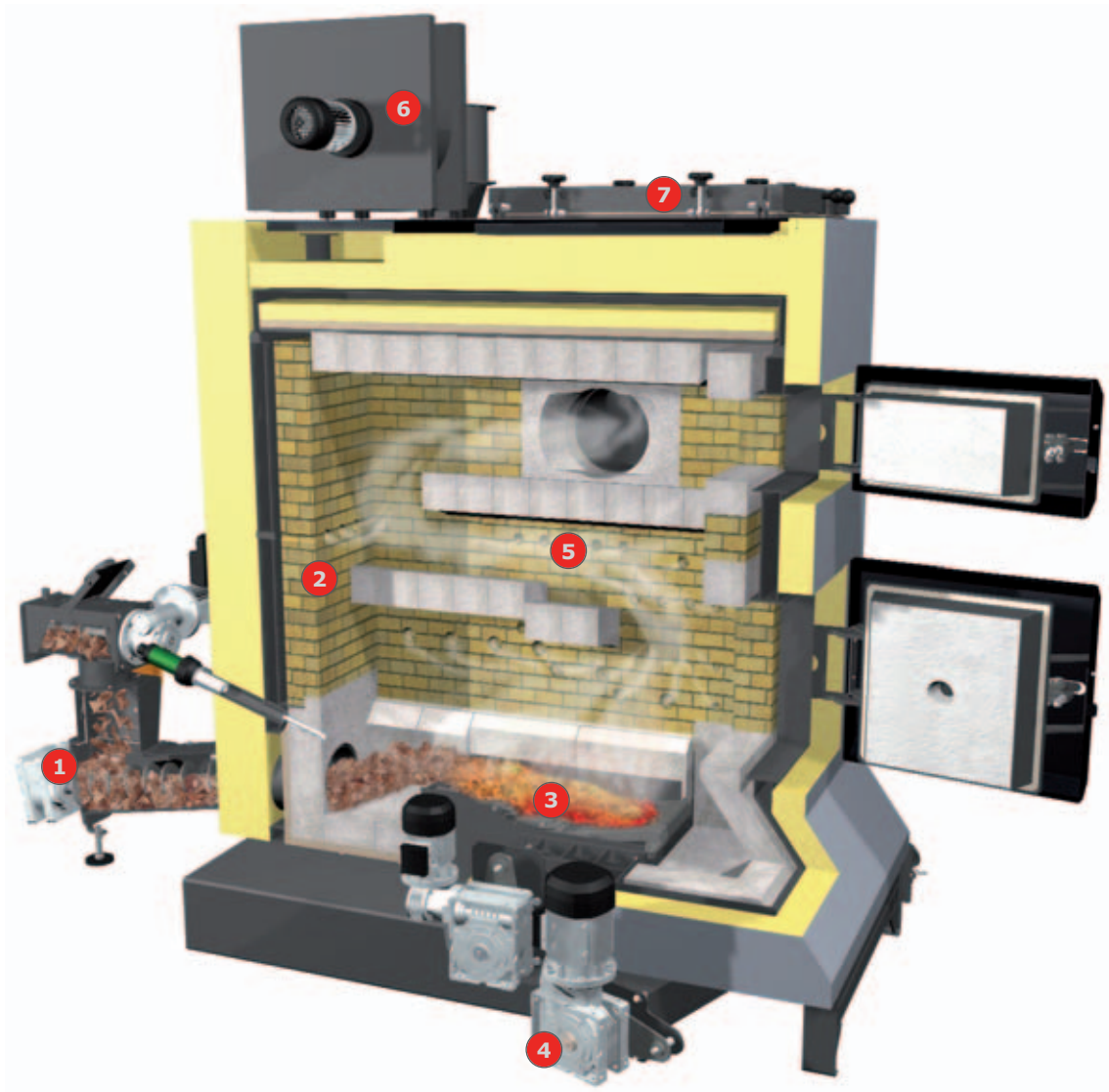

- 1 Different stoker dimensions can be chosen to fit different fuel characteristics perfectly.
- 2 High-temperature resistant fireclay retort with long burnout zone for clean combustion and low emission values.
- 3 The newly developed troughed underfeed stoker offers the option of modular expansion with a high-quality conveyor grate for optimum fuel adjustment.
- 4 Automatic ash removal and the option of combination with very different automatic types of ash removal (standard ashcan, underfloor ash removal, etc.).
- 5 Air supply with integrated tertiary air control as standard for optimum burnout.
- 6 Optional flue gas recirculation for optimisation of combustion and output.
- 7 Vertical 4-pass heat exchanger with integrated cyclone dust separator and Efficiency Optimisation System (WOS) including automatically activated turbulators for cleaning.



# Better heating

**Feature:** **Troughed underfeed stoker with conveyor grate**

- Benefits:
- No cinder build-up
  - Optimum burnout
  - Very low emissions
  - Automatic ash removal

The troughed underfeed stoker designed for the Turbomat Industrie ensures optimum material collection and pre-drying in the high-quality fireclay-covered combustion trough. The best possible burnout is achieved through regulated tertiary air as standard. The optional flue gas return regulates the temperature of the glowing ember bed and guarantees a long service life for the fireclay combustion chamber.

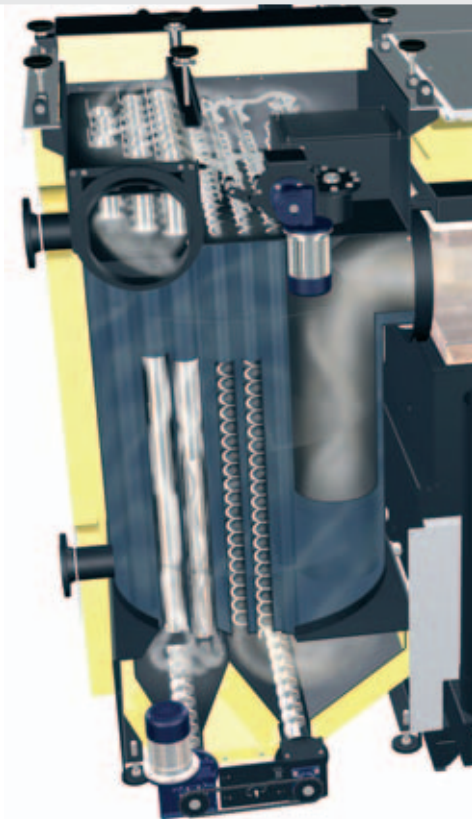

**Feature:** **Upright heat exchanger**

- Benefits:
- Optimal heat transfer
  - Automatic cleaning of heating surfaces
  - High efficiency
  - Very low dust emissions

The established heat exchanger design of the Turbomat Kommunal was taken and adapted for the Turbomat Industrie. The upright design means that the heat-exchanger practically cleans itself. The heating surfaces can also be cleaned automatically to achieve high efficiency.

The built-in safety battery prevents over-heating. The patented multi-cyclone dust separator integrated in the heat exchanger ensures that the lowest dust emission values are observed. Ash removal is performed by worm screws, which feed ash straight to the container. These are outside the unit, so they are easy to remove and empty.

## Performance data - TM Industrie 320/500

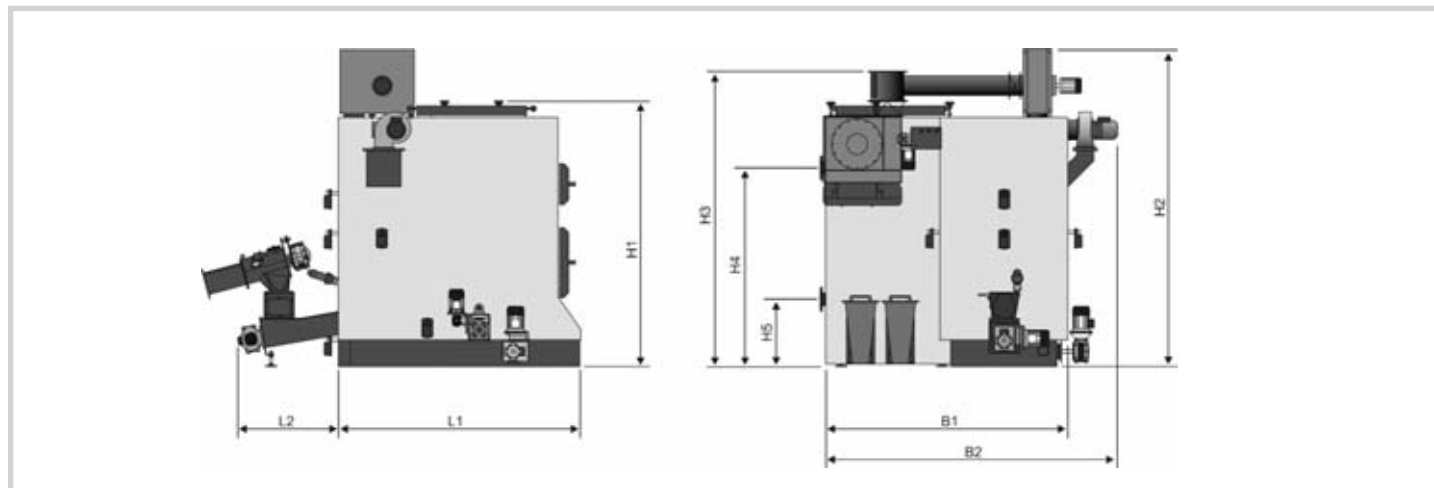

DIMENSIONS			TM 320	TM 500
H1	Height of boiler	[mm]	2450	2605
H2	Overall height	[mm]	2940	3075
H3	Height of flue gas pipe connection	[mm]	2730	2910
H4	Height of outfeed connection	[mm]	1830	1980
H5	Height of return feed connection	[mm]	620	690
W1	Width of boiler	[mm]	2230	2670
B2	Total width of the system	[mm]	2690	3150
L1	Length of boiler	[mm]	2235	2470
L2	Length of stoker unit	[mm]	925	990

TECHNICAL SPECIFICATIONS			TM 320	TM 500
Rated heat output (woodchips W30 as per ÖNORM)		[kW]	320	500
Required fuel consumption at rated load (G50/W20)		[kg/h]	110	172
Weight - boiler		[kg]	5220	7650
Flue gas pipe diameter		[mm]	300	350
Water capacity		[L]	560	750
Maximum permitted boiler operating temperature		[°C]	110	110
Minimum return feed temperature		[°C]	65	65
Maximum permitted operating pressure		[bar]	6	6
Flue gas temperature at rated load		[°C]	140	140

# Controls and feed

## **Feature:** Lambdatronic controller

- Benefits:
- Optimum combustion control
  - Adapts to very different fuel characteristics
  - Savings through optional remote servicing

The modular design of the Lambdatronic control system ensures optimised combustion. The boiler automatically adjusts to the particular characteristics of the fuel being used. The Lambdatronic provides trouble-free, weather activated control of heating circuits and precise control of the various storage systems. Servicing can be carried out with remote control by Froling via modem. This not only saves you time, but it will also save you money and is environmentally friendly. The Lambda control system with precision primary, secondary and tertiary air control, the combustion chamber temperature monitoring system, the under-pressure control system (which monitors the intensity of the glowing ember bed) and the flue gas recirculation system all ensure optimum combustion.



## **Feature:** Froling boiler display software

- Benefits:
- Monitoring and operation from a PC
  - Records the boiler data
  - Remote control via modem

The optional boiler display software enables easy boiler control from a computer. All operating values and customer parameters can be displayed and changed. The standard Windows interface and the clear menu structure guarantee ease of use.

It is possible to connect to the boiler display software over the telephone network using a modem. This means that the heating system can be monitored from any location.





## Froling feed systems - Refined over decades

Froling has many years of experience designing feed systems. Regardless of whether the systems are large or small, Froling provides rugged infeed systems, which meet the highest technical standards. For example, it is possible to connect a hydraulic infeed system to the Turbomat 320 Kommunal or the Turbomat 500 Kommunal, which is especially well suited for bulky or bundled fuels.



### Industrial articulated arm feed unit:

Ensure problem-free, fully automatic operation. The energy and maintenance costs are kept to a minimum. The special shape of the trough and the feed screw with progressively rising screw blade ensure reliable fuel feed. The system is easy to operate so it saves energy even when feeding in the maximum amount of pellets.

### Inclined screw feed unit:

Mainly used as a silo feed screw in the wood-processing industry. Ensures even and reliable fuel feed from high silos.



### Horizontal screw feed unit:

Solid construction to withstand extremely high feed loads when feeding high silos. This is especially used for shavings and large diameter bunkers.

### Pusher feed unit:

The variant for rectangular stores is suitable for all commonly used biomass fuels. The pusher feed unit has proven particularly effective for fuel feed from large woodchip stores.

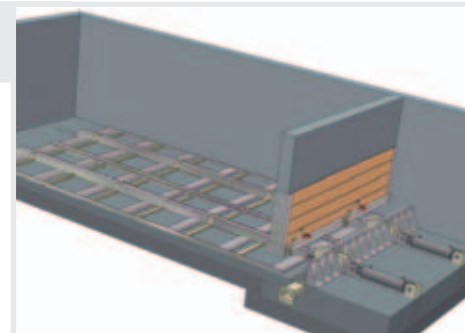

# In use across Europe



## ENGLAND - Ampleforth College

Year of construction: 2004  
Boiler: Turbomat 320 kW  
Feed system: Articulated arm feed unit / diameter 4 metres  
Fuel: Wood chips



## SWEDEN - Tre Sagar

Year of construction: 2005  
Boiler: Turbomat 220 kW  
Feed system: Articulated arm feed unit / diameter 5.7 metres  
Fuel: Wood chips



## GERMANY - Schloss Gaußig

Year of construction: 2006  
Boiler: Turbomat 220 kW  
Feed system: Hydraulic pusher feed unit with transverse conveyor unit  
Fuel: Wood chips



## SPAIN - Cantabria

Year of construction: 2007  
Boiler: 2x Turbomat 150 kW - double boiler system  
Feed system: Articulated arm feed unit / diameter 5 metres  
Fuel: Wood chips

Further technical details available on request.  
We'll be happy to advise you.



Shaw Renewables Limited  
Place Farm House  
Warrington Rd, L35 6PG

[www.shawrenewables.co.uk](http://www.shawrenewables.co.uk)  
[info@shawrenewables.co.uk](mailto:info@shawrenewables.co.uk)  
0151 424 1433

P0330009 - All illustrations intended as a guide only.  
We reserve the right to make technical changes without prior notice. Errors and omissions  
excepted.  
Source for external image material: [www.aboutpixel.de](http://www.aboutpixel.de), [www.pixelio.de](http://www.pixelio.de)



**Heizkessel- und Behälterbau GesmbH**  
**A-4710 Grieskirchen, Industriestr. 12**

Tel +43 (0) 7248 606 • Fax +43 (0) 7248 606-600  
E-mail: [info@froeling.com](mailto:info@froeling.com) • Website: [www.froeling.com](http://www.froeling.com)